

The EIB Power Supply produces and monitors the EIB system voltage. The bus line is decoupled from the power supply with the integrated choke.

The power supply is connected to the bus line with a bus connection terminal. A reset is triggered by pressing the reset push button and lasts for 20 seconds (regardless of the duration of the push button action). The bus line is disconnected from the power supply and the bus devices connected to this bus line are returned to their initial state. If the line should be disconnect-

ted for a longer period, the bus connection terminal must be removed from the power supply.

A 30 V DC auxiliary voltage is made available via an additional connection terminal. This voltage can be used to supply a further bus line (in connection with a separate choke). The 30 V DC auxiliary voltage may not be used for other purposes.

Technical data

Power supply	– Power supply	230 VAC +10/-15%, 45 ... 65 Hz
	– Power consumption	< 45 VA
	– Power loss	< 6 W
Outputs	– EIB output	1 line with integrated choke
	– EIB nominal voltage	30 VDC +1/-2 V, SELV
	– Auxiliary voltage output	1 (without choke)
	– Auxiliary voltage	30 VDC +/- 1 V, SELV
	– Nominal current (total of EIB and auxiliary voltage output)	640 mA, short-circuit-proof
	– Sustained short-circuit current	< 1.5 A
	– Mains failure back-up time	200 ms
Operating and display elements	– Green LED	„ON“: output voltage is OK
	– Red LED	„ > _{max} “: overload or short circuit
	– Reset push button	Reset at the EIB output (starts when the push button is pressed and lasts 20 s)
	– Red LED	Reset at the EIB output
Connections	– Power supply	3 screw terminals Cable cross-section: multi-core 0.2 – 2.5 mm ² single-core 0.2 – 4.0 mm ²
	– EIB output	Bus connection terminal (black/red)
	– Auxiliary voltage output	Connection terminal (yellow/grey)
Type of protection	– IP 20, EN 60 529	
Ambient temperature range	– Operation	– 5 °C ... + 45 °C
	– Storage	– 25 °C ... + 55 °C
	– Transport	– 25 °C ... + 70 °C
Design	– Modular installation device, proM	
Housing, colour	– Plastic housing, grey	
Mounting	– On 35 mm mounting rail, DIN EN 50 022	
Dimensions	– 90 x 108 x 64 mm (H x W x D)	
Mounting depth/width	– 68 mm/ 6 modules at 18 mm	
Weight	– 0.35 kg	
Certification	– EIB-certified	
CE norm	– In accordance with the EMC guideline and the low voltage guideline	

Wiring diagram

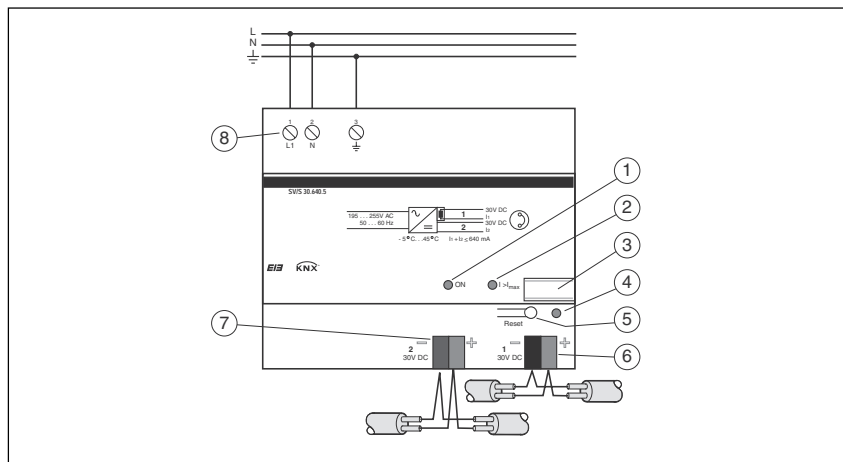

- | | |
|------------------------------------|--|
| 1 Green LED (output voltage OK) | 6 Bus connection terminal (EIB output) |
| 2 Red LED (overload/short circuit) | 7 Connection terminal (auxiliary voltage output) |
| 3 Label carrier | 8 Mains supply |
| 4 Red LED (reset) | |
| 5 Reset push button | |

Note

Switch on the mains voltage once the device has been correctly installed. The green „ON“ LED lights up. All the other LEDs are switched off. The device is functioning correctly.

The auxiliary voltage may not be used for other purposes (e.g., to connect sensors to a binary input) as both the power supply and the connected EIB line will fail in the event of a fault at the auxiliary voltage output (e.g. a short circuit)!

Device application

The EIB Power Supply SV/S 30.640.5 is particularly suitable for the supply of:

- lines with up to 64 bus devices, e.g., detached houses, office buildings, commercial buildings.
- lines with a small number of devices and the simultaneous supply of a main line or area line via the separate 30 V DC auxiliary voltage output in combination with an additional choke.

Application example

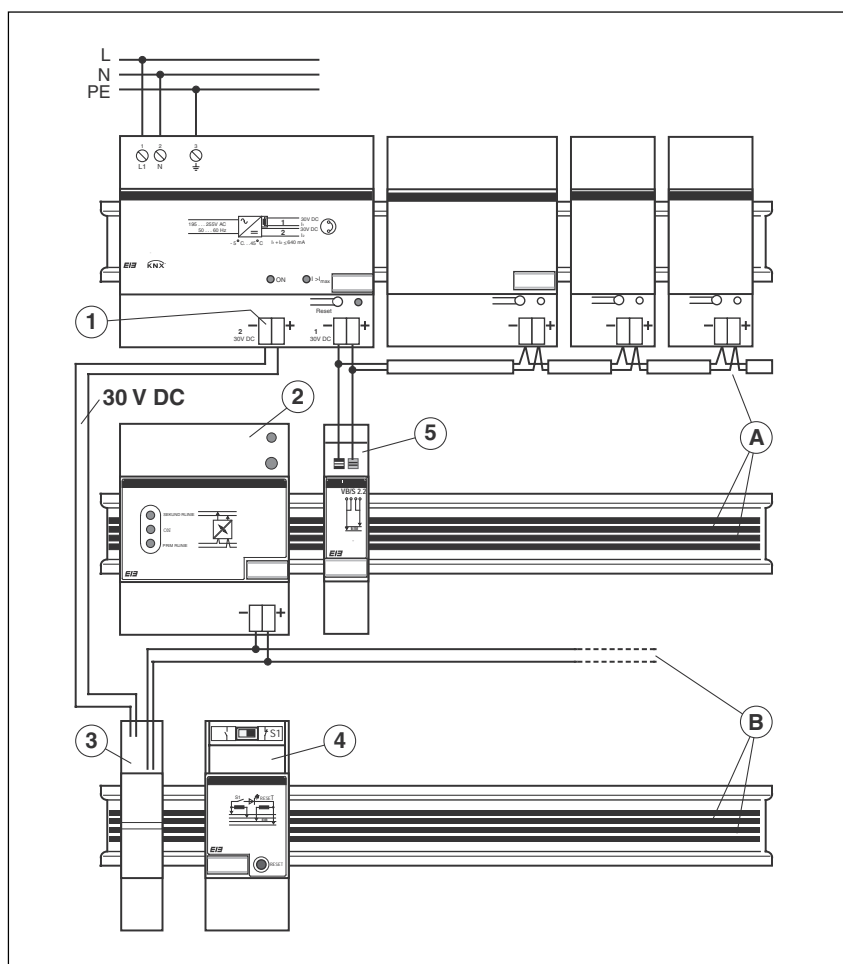

A Line 1

B Main line

- 1 Connection terminal
- 2 Line coupler
- 3 Connector, 4-pole

- 4 Choke
- 5 Connector, 2-pole

Reset

To carry out a reset, press the reset push button. The red „Reset“ LED lights up. The reset lasts approx. 20 seconds, regardless of the duration of the push button action. The bus line is disconnected from the power supply and the bus devices connected to the bus line are returned to their initial state. The „Reset“ LED extinguishes when the reset has finished.

If the line should be disconnected for a longer period, remove the bus connection terminal from the EIB power supply.

Fault

During normal operation, the green „ON“ LED lights up.

If only the red LED „ I_{max} “ lights up, the EIB output has experienced an overload or short circuit. Rectify the short circuit or reduce the number of bus devices if necessary until an overload is no longer present and only the green „ON“ LED lights up.

If the green „ON“ LED and the red LED „ I_{max} “ light up simultaneously, the bus line has experienced an overload and the correct function cannot be guaranteed. Reduce the number of bus devices until the overload is no longer present and only the green „ON“ LED lights up.

If neither LED lights up, the mains voltage is disconnected. Connect the voltage to the system and carry out a reset.

Once the fault has been rectified, carry out a reset by pressing the reset push button.